



Modular

walk-in chambers 

acstestchambers.com





Angelantoni Test Technologies
stay ahead to meet the needs
of the Industry of the Future, where

Internet Technology,

Remote Connections,

Communication & Networking

are the keywords for success.



Modular walk-in chambers

ACS is proud to announce the **new release** of its standard modular walk-in chambers.

Besides the well-known key features - **modularity, flexibility, easy assembly** - these chambers are now equipped with the new cutting-edge **MyKratos™** control system, which makes it possible to manage, monitor and assist the chamber from mobile and desktop devices using Wi-Fi, Ethernet, or mobile network connections. This line of chambers comes in both thermostatic (temperature only) and climatic (temperature and humidity) versions.

fast delivery

easy to assemble and disassemble

rapid upgrade

simple to refurbish

remote assistance 24/7

Mix and match to better fit your needs

Without compromising our high standards of quality and reliability, we wanted to reduce delivery times and avoid the costs of design and engineering normally associated with the customized walk-in chambers.

Modular design is the solution.

A cost-effective, modular design comprising the four basic elements of a walk-in chamber that can be mixed and matched to provide a configuration to suit most requirements.

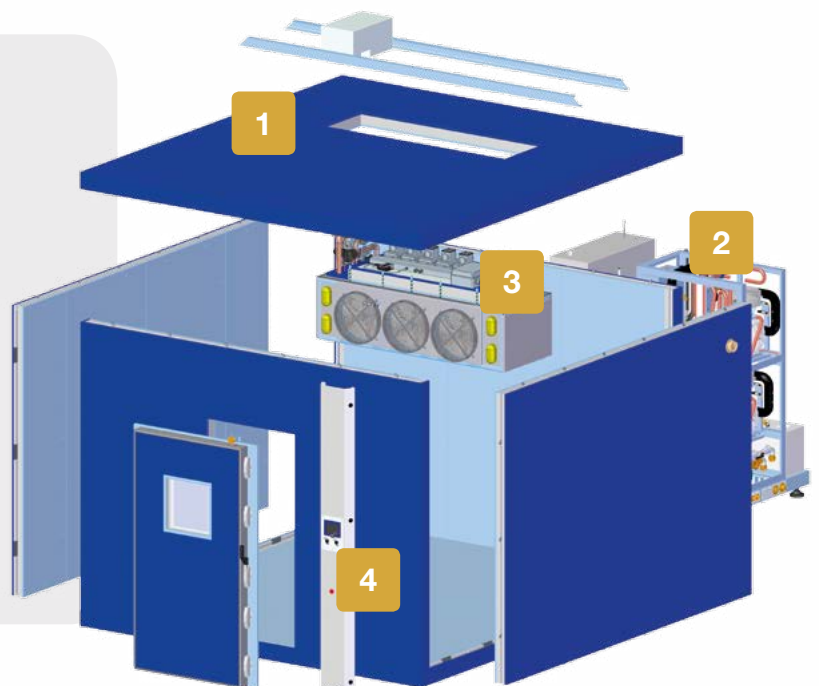

1 Test Room Construction

Vapor tight prefabricated panels suitable for multiple assembly and take down operations, AISI 304 interior, blue plastic coated zincor steel exterior. Insulation thickness: 120 mm.

2 Cooling Unit

Comprising the cooling unit and the humidification system required for the control of temperature and air humidity inside the walk-in chamber. The basic version requires either mains water or tower water for cooling.

3 Air Treatment Unit

Powerful fans draw the chamber air across the heat exchangers for cooling and dehumidification, heaters and control sensors before recirculating the conditioned air back into the chamber. A Pt100 sensor (temperature) and a capacitive probe (humidity) are used for control.

4 Innovative Control System

Industry demands smart solutions for managing and maintaining distributed networks of people, machines, and processes. The ACS solution for the Internet of Things is the **unique-in-the-market MyKratos™ software**, making it possible to manage, monitor and assist a test chamber in any place at any time, from mobile and desktop devices, using any kind of connection (Wi-Fi, Ethernet or mobile networks).

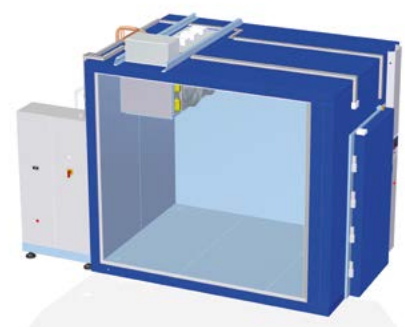

Modular walk-in chambers make your life easier!

- ✓ Flexible and modular design for a wide production range.
- ✓ Strong standard floor 3000 Kg/m².
- ✓ Robust self-supported structure.
- ✓ High degree of customization through many accessories (portholes, door inspection windows, double wing door).
- ✓ Quick assembling on site.
- ✓ Quick disassembling to relocate or rebuild the chamber if necessary.
- ✓ Easy upgrading and refurbishing thanks to unit plant and air treatment modularity.



| 5



Check out our video about easy assembly at www.acstestchambers.com

Modular walk-in chambers

6 |



Customized walk-in chambers

A wide range of solutions are available for any customer requirements. Our company has extensive experience in supplying equipment for applications in such diverse fields as electronics, aeronautics, automotive, home appliances and defence.

Walk-in chamber equipped with indirect cooling system to test specimen (base station) with high heat dissipation



Walk-in chamber for rain tests



Walk-in chamber for tests on satellite antennas and panels



Calorimeter to measure the efficiency of air conditioning systems



Focus on basic features

Modular walk-in chambers come with a wide range of included accessories

Basic Configuration

- **MyKratos™** including **MyAngel24™**
- Single wing door
- **Skidproof floor:** stainless steel floor with anti-slip surface treatment
- **Closing:** mechanical
- **Thermostat:** max./min. digital thermostat with independent probe
- **Auxiliary contacts** (specimens, alarms)
- **Interface:** Ethernet port for remote control system connection and USB port for operator panel
- **Water condenser**

Options

- **Inspection window for single wing door:** multiple-crystal, with double heated transparent film, 450x450 mm size **1**
- **Double wing door:** with 2 heated multi-pane windows with double transparent film, 450x450 mm size **2**
- **Additional portholes:** no. 2 Ø150mm portholes, number and positions available as per drawings **3**
- **Set of 4 input PT100 (max 1 set)** (no. 1 set max)
- **Set of no.4 analogic inputs:** 0÷10V for user's data acquisition (no. 1 set max)
- **Set of no. 8 auxiliary contacts** (no. 1 set max)
- **No break power unit for PLC**
- **Specimen switching off** in case of chamber alarm
- **Remote air condenser**
- **MyKratos™ Multichamber software:** installed on a PC, for monitoring and control multiple chambers (to be supplied upon request)

8 |



1 Inspection window on the door



2 Double wing door



3 Panel with n°2 portholes (Ø150 mm internal size)

Modular basic elements

Test room

	Useful capacity (m ³)	Internal dimensions approx. (mm)			External dimensions approx. (mm)		
		Width	Depth	Height	Width	Depth	Height
Compact	10	2120	1820	2560	2360	2060	2800
Medium	16	2120	3000	2560	2360	3240	2800
Large	30	3300	3640	2560	3540	3880	2800
Extra large	40	3300	4820	2560	3540	5060	2800

Compact

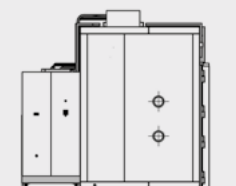

Medium

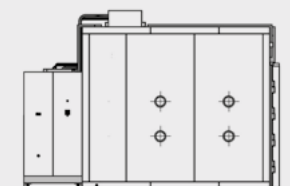

Large

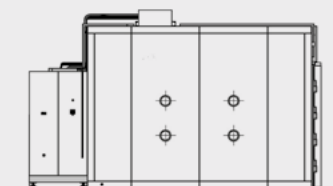

Extra large

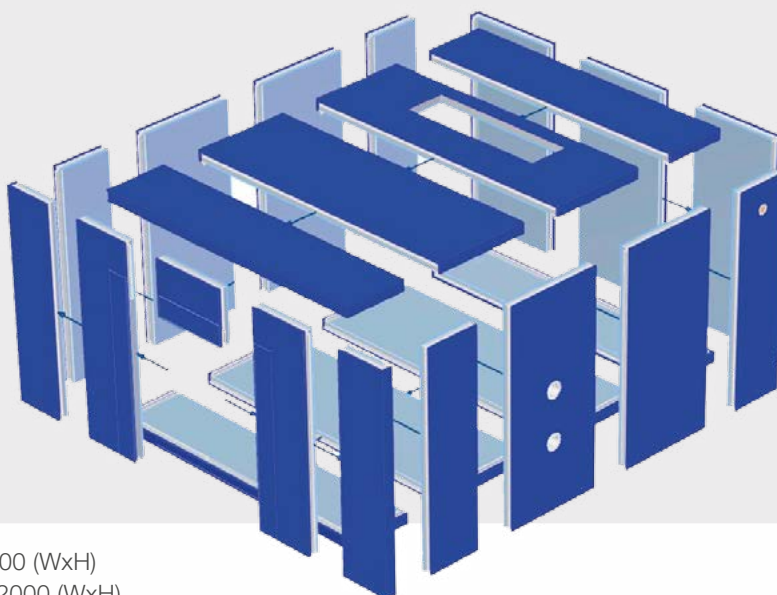
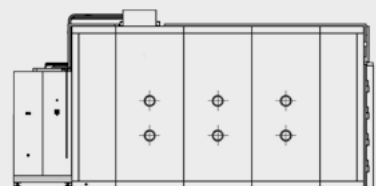

Single wing door useful dimensions: 900x1900 (WxH)

Double wing door useful dimensions: 2000x2000 (WxH)

Portholes are positioned in the center of the panel at fixed height.

The drawing shows the right side panels, but the same configuration is available also on the left side.

Right and left panels having the same dimensions, either blind or with Ø150 mm portholes, are interchangeable.

The double porthole panel position and side can be decided by the customer during installation.

Each test room standard size is compatible with any air treatment unit type.

Air treatment units dimensions: 1965x800x570 mm (WxDxH)

Cooling units dimensions: 2000x1210x2070 mm (WxDxH)

Air treatment and cooling units

Capacitive probe (electronic system)

Direct humidification takes place by means of an electric humidifier placed in the cooling unit and a steam distributor located in the air treatment unit. Dehumidification takes place in the air treatment unit through a dedicated battery.



Humidity diagram

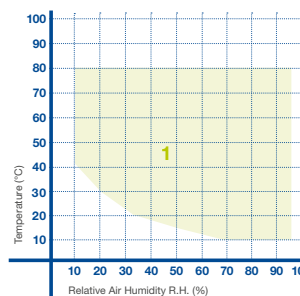

1. Standard working range

	MODEL ¹	WZH A1	WZH B1	WZH C1	WZH A2	WZH B2	WZH C2
Temp. changing rate Heating ⁴⁺⁵ (K/min)	Compact	2,7 ^{note 7}	5,2 ^{note 7}	5,5 ^{note 7}	2,7 ^{note 10}	5,2 ^{note 10}	5,5 ^{note 10}
	Medium	2 ^{note 7}	3,8 ^{note 7}	5,5 ^{note 7}	2 ^{note 10}	3,8 ^{note 10}	5,5 ^{note 10}
	Large	1,2 ^{note 8}	2,5 ^{note 7}	3,7 ^{note 7}	1,2 ^{note 10}	2,5 ^{note 10}	3,7 ^{note 10}
	Extra large	1 ^{note 8}	2,1 ^{note 7}	3 ^{note 7}	1 ^{note 9}	2,1 ^{note 10}	3 ^{note 10}
Temp. changing rate Cooling ⁴⁺⁵ (K/min)	Compact	1,1 ^{note 7}	1,9 ^{note 7}	2 ^{note 7}	1,5 ^{note 10}	2,6 ^{note 10}	2,8 ^{note 10}
	Medium	0,8 ^{note 7}	1,4 ^{note 7}	2 ^{note 7}	1,1 ^{note 10}	1,9 ^{note 10}	2,8 ^{note 10}
	Large	0,5 ^{note 8}	0,9 ^{note 7}	1,4 ^{note 7}	0,7 ^{note 10}	1,3 ^{note 10}	1,9 ^{note 10}
	Extra large	0,4 ^{note 8}	0,8 ^{note 7}	1,2 ^{note 7}	0,5 ^{note 9}	1 ^{note 10}	1,6 ^{note 10}
Humidity range (%) ²		10...95	10...95	10...95	10...95	10...95	10...95
Temperature range for climatic test (°C)		10...80	10...80	10...80	10...80	10...80	10...80
Humidity fluctuation (%)		±3...±5	±3...±5	±3...±5	±3...±5	±3...±5	±3...±5
Maximum thermal Load (W) ⁵	T=+25°C	2000	5000	9000	3000	6000	10000
Rated power (kW)		25	39	53	28	44	60
Rated current absorption (A)		45	67	91	52	76	108
Weight (without packing) (kg)	Compact	2050	2250	2400	2300	2650	3000
	Medium	2300	2500	2650	2550	2950	3250
	Large	2800	3000	3150	3050	3450	3750
	Extra large	3150	3300	3500	3400	3750	4100
Sound pressure level dB(A) ³		68	72	76	72	76	80
Max water consumption (m ³ /h) ⁶		2,3	4	6,5	2,9	5,1	8,2
Supply voltage (Vac)		400V ±10%/50Hz/3 + N + G					

- For Temperature only version change the prefix WZH with WZT
- t=+4°C/+78°C for continuous test
- Measured at 1 m distance in front of the unit in 1,6 m height, free field measurement

- According to IEC 60068-3-5 and IEC 60068-3-6 in the temperature range +80/-30°C
- The performance data refer to +22°C ambient temperature, 400V nominal voltage, without specimen
- With water at T +29°C and temperature difference

- at 5°C (water temperature range +12÷+29°C)
- Temperature range (-40/+80°C)
- Temperature range (-30/+80°C)
- Temperature range (-65/+80°C)
- Temperature range (-70/+80°C)

mykratos

an intelligent Control System ready for the Future

Thanks to their hyper-connectivity, ACS test chambers can match current and future needs related to the new demands of the Industrial Internet of Things and Industry 4.0 for integrated, interconnected and communicating machines.

Embedded Control Software

MyKratos™ inside, to control monitor and assist the chamber. No additional hardware or software required

Free App

to fully manage the chamber via mobile devices (Google Play and Apple Store)

Easy remote access and control

via integrated Wi-Fi / mobile network and Ethernet

Chamber Internal Cloud

for data storage

The chamber is equipped with a **PLC** (Programmable Logic Controller) for managing all the chamber's functions and safety interlocks. A special device (**Gu@rdian Evo**) controls the chamber via "mobile" devices, such as Tablets and Smartphones, or by establishing a remote Internet connection. The HMI system consists of an on-board panel (**Keykratos Evo**) and a remote control (**MyKratos™** including **MyAngel24™**) connected to the chamber.

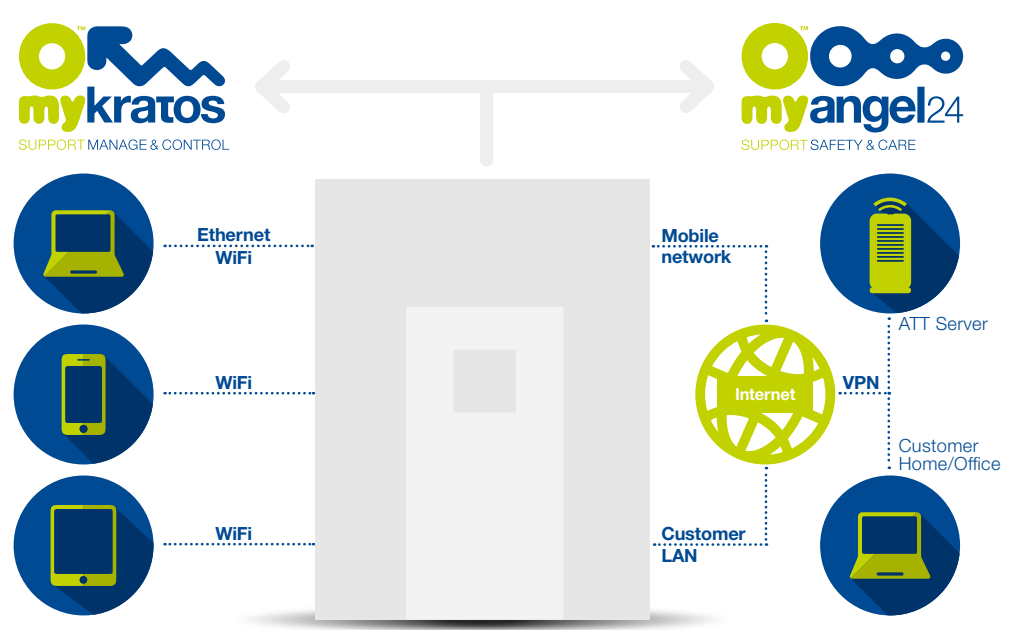

KeyKratos Evo on board panel

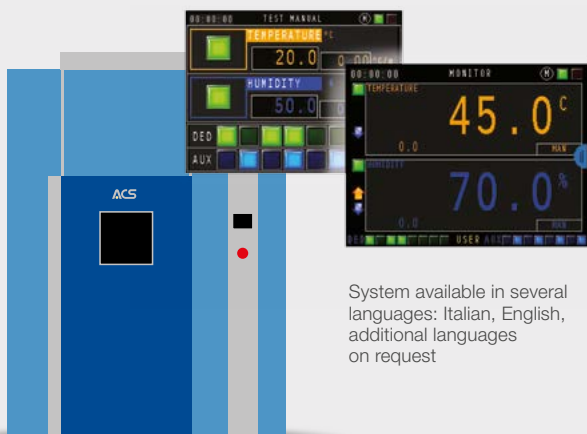

System available in several languages: Italian, English, additional languages on request

Hardware

- 5.7 inch 65,536 color Analog Touch Panel with TFT technology
- Faster control

Software

- Touch menu with related pop up screens where necessary
- Manual chamber control
- Possibility to start the last stored profile
- Alarms Notification
- Main chamber's parameters setup

MyKratos™ control system

MyKratos™ control software makes it possible to manage, monitor and assist the chamber anywhere, at any time, in multiple ways (Wi-Fi, Ethernet, mobile network) via mobile and desktop devices. The chamber wireless (Wi-Fi) connection permits operation using tablets and smartphones (iOS 8 or Android 4.2.1 compatible). The operator interface can also be remotely accessed through a chamber connection to the client's LAN or via mobile network (on activation of a SIM card data). It includes the **MyAngel24™** remote-assistance system.

Main features

- Wi-Fi or Ethernet connection to the chamber
- Visualization and graphical analysis of measures and recordings
- Synoptic charts of the entire system
- Multilanguage support
- High configurability of chamber parameters
- Unlimited measures recording possibilities
- Program and Manual chamber operation modes
- Delayed start of a program
- Possibility to select more than one chamber from a single Tablet: secure access by means of multiple password levels
- Automatic notifications of event and alarms
- Archive manager for easy access to the stored recordings
- Possibility to send email notification
- Possibility to send SMS notification (SIM card required)
- Multi-chamber management

12

Additional S/W tools for an Easy Integration of ACS test chambers in Test Labs

Communication drivers for an easy integration into customer-developed Serial or Ethernet based applications, (LabVIEW, LabWindows CVI, Microsoft.NET, Visual Basic 6, etc...) can be supplied on request. The drivers come with a set of examples written in Visual Basic 6, LabView, LabWindows CVI, VB.NET, and permit total interaction with ACS test chambers, for both reading and writing.

Our communication protocol - ModBUS RTU for serial or Fetch/write for Ethernet communication, can be supplied to allow any chamber connection using the customer's own programming languages and operating systems.

Example program LabVIEW

User interface

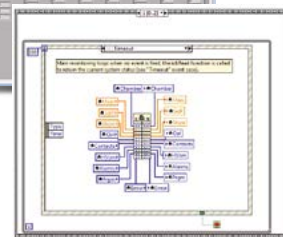
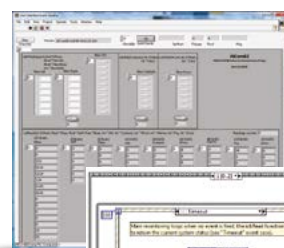

Development environment



MyKratos™ App free download

Available on the iPhone
App Store

ANDROID APP ON
Google play

MyAngel24™ remote assistance system



MyKratos™ software includes the innovative ACS remote-assistance system **MyAngel24™**, operating via mobile network wireless connection, complete with SIM card. This makes it possible to access the operator interface remotely via VPN and send **SMS notifications**. Cabled connection is also available, via customer's LAN. N.B.: MyAngel24™ activation on demand



With **MyAngel24™**, the climatic chambers stay connected to the remote server 24 hours a day, monitoring running conditions in order to guarantee faster and more efficient service and maintenance activities.



With **MyAngel24™**, you can stay in contact with the climatic chamber whenever you want and wherever you are, accessing its control panel from any web browser.



MyAngel24™ uses the highest security standards available for authentication, secure connection, data encryption and storage. Moreover, you can suspend or limit the data sent to the central server for security reasons during one or more test sessions.

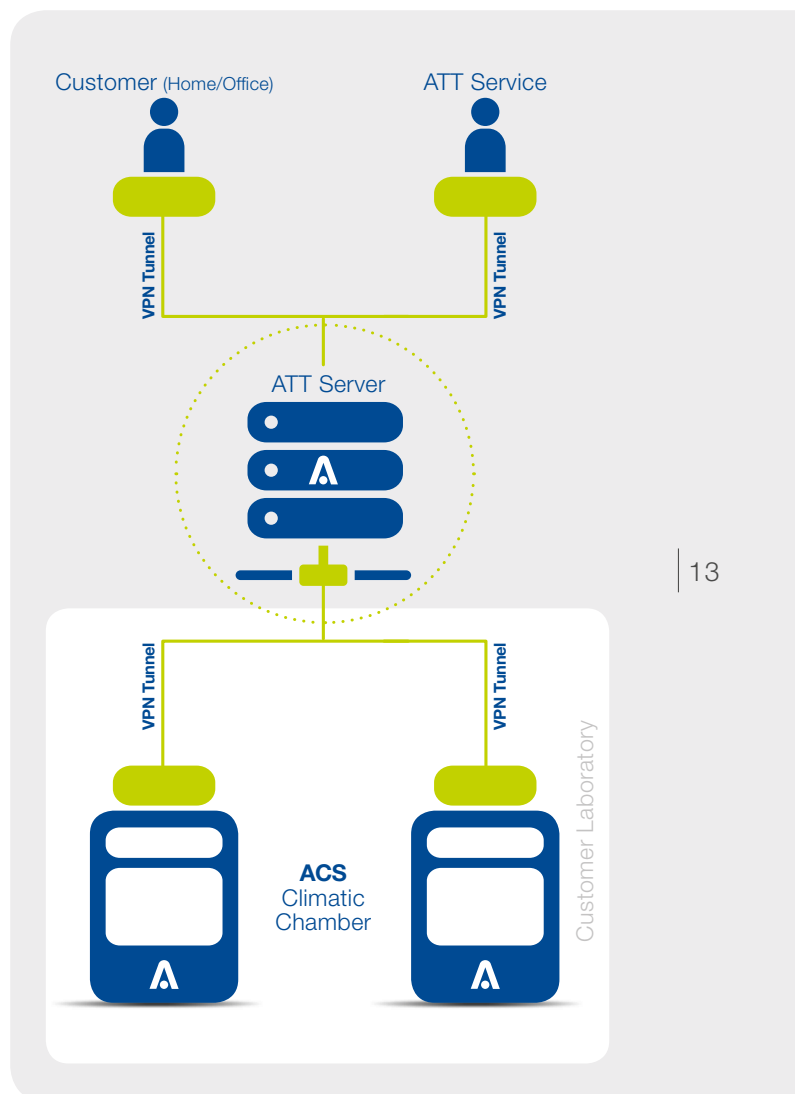

Hardware and software infrastructure

4 simple steps for assistance and complete remote control

The remote server

located at Angelantoni headquarters (in Massa Martana, Perugia) hosts the database for data storage and acquisition.

The climatic chamber

is equipped with an electronic device functioning as an integrated system, allowing for connection to the remote server.

The remote connection

is created by connecting the climatic chamber to the VPN by mobile network, or on request by Ethernet connection to an enabled company LAN.

The company network connection

can be set up through a web browser, with access regulated according to a hierarchy of authentication privileges.



Angelantoni Test Technologies, owned by the **Angelantoni Group**, is the only company capable of offering a comprehensive range of environmental test chambers - **ACS** branded - for a great variety of applications, thanks to the expertise and technical know-how of its teams of experts. Innovation, flexibility and organization have always been the keys to success for ACS, world-famous since 1952 also for its high-tech test equipment such as Thermal High Vacuum Chambers for Aerospace applications and Calorimeters.



Angelantoni Test Technologies
Località Cimacolle, 464
06056 Massa Martana (Pg) - Italy
Tel. +39 075.89551 (a.r.)
Fax +39 075 8955200
info@acstestchambers.it

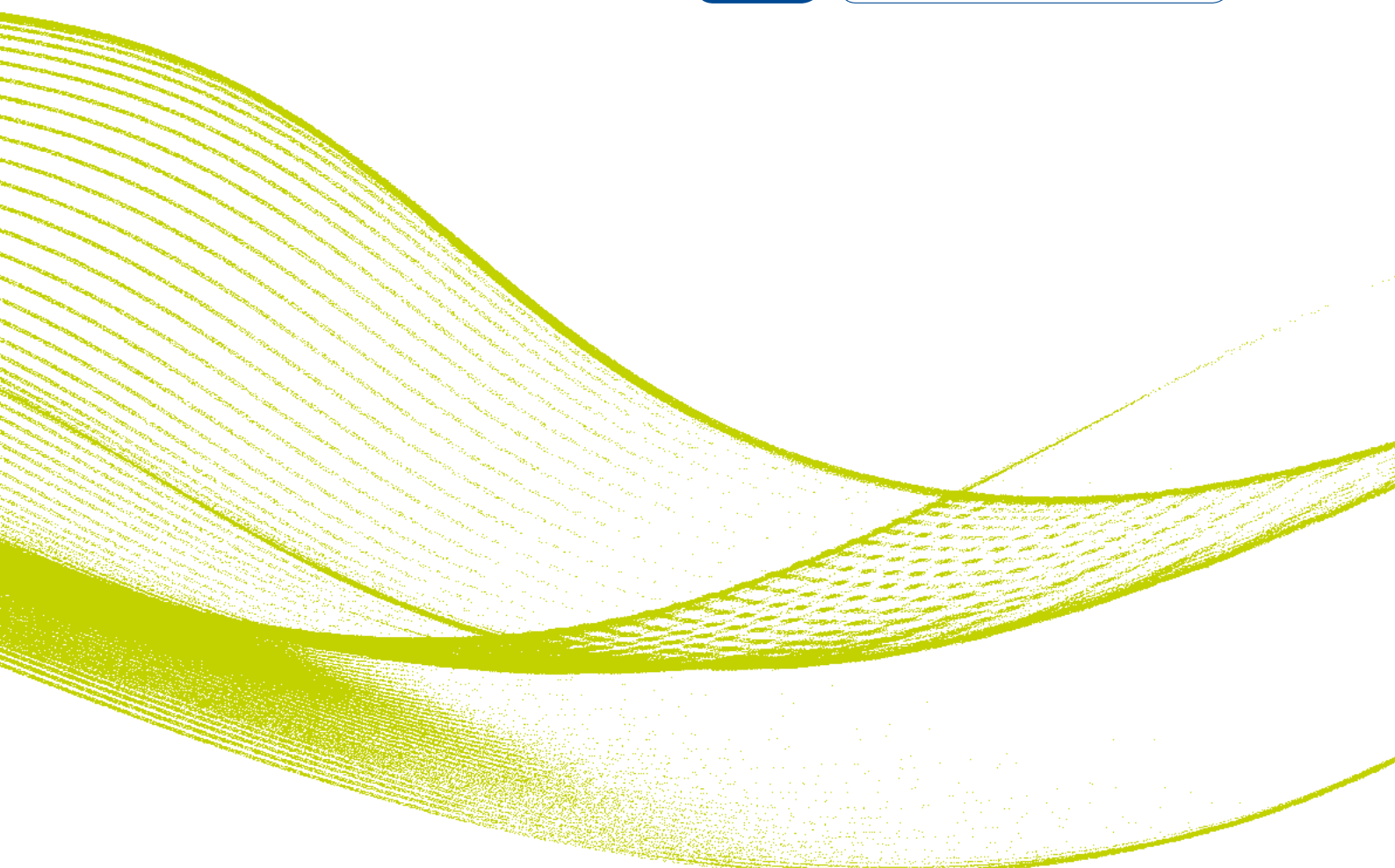

Angelantoni
MORE THAN YOU THINK



Angelantoni Test Technologies

Loc. Cimacolle, 464 - 06056 Massa Martana (Pg) - Italy
Tel. +39 075.89551 (a.r.) - Fax +39 075 8955200
info@acstestchambers.it

www.att-testing.com
www.acstestchambers.com

Subsidiaries
Ofterdingen, GERMANY
info@att-umweltsimulation.de

Noida, INDIA
info@attindia.in

Beijing, P.R. CHINA
info@attasiapacific.com

